



 **UMBROSA**<sup>®</sup>  
UNIQUE SHADE DESIGN

## UNIQUE SHADE DESIGN

### Something new under the sun

Sun means life. The sun invites us to get outside. The sun seems to expand the world we live in. But when the sun shines just a little bit too brightly, you long for a place in the shadow. Parasol literally means 'to keep the sun out'. An Umbrosa on the contrary creates shadow. It allows you to keep enjoying the sun. For both the residential and the project market, Umbrosa is not afraid to reinvent existing products. Our shadow creations stand out among the rest because of their shapes and functions. They are robust, easy to open and close and they require little maintenance. Their design is accessible and playful and always comes with a cheeky smile that helps break the dullness. They are just different. They are unique, just like you. Umbrosa is your guarantee for affordable luxury, durable Belgian quality and reliable functionality. Ingeniously made shadow creations as the ultimate finishing touch in your garden or on your patio.

### FR/ Du neuf sous le soleil

Le soleil fait vivre, il nous invite à sortir. Le soleil élargit nos horizons. Mais lorsqu'il se montre trop ardent, le besoin d'ombre se fait sentir. Parasol signifie littéralement 'repousser le soleil'. Un Umbrosa, lui, crée de l'ombre. Vous pouvez ainsi continuer à profiter du soleil. Umbrosa ose réinventer des produits existants, tant pour le marché particulier que pour celui des projets. Nos créations d'ombrage brillent par leur forme et leurs fonctionnalités. Elles sont robustes, faciles à ouvrir et à fermer et elles n'exigent que peu d'entretien. Leur design est accessible et ludique, signées d'une petite touche qui brise la monotonie. Elles sont tout simplement différentes. Uniques. Comme vous. Umbrosa vous garantit un confort abordable, une qualité belge durable et une fonctionnalité fiable. Des créations d'ombrage ingénieusement conçues, offrant la touche finale ultime à votre jardin ou votre terrasse.

### DE/ Etwas Neues unter der Sonne

Sonne ist Leben. Die Sonne lädt uns ein, nach draußen zu kommen. Sie erweitert unseren Lebensbereich. Doch wenn die Sonne ein wenig zu kräftig hervorkommt, sehnen Sie sich nach einem Plätzchen im Schatten. „Parasol“ bedeutet wörtlich „die Sonne abwehren“. Ein Umbrosa dagegen spendet Schatten. So dass Sie die Sonne weiterhin genießen können. Sowohl für den Privatbereich als auch den Projektmarkt schafft Umbrosa es, vorhandene Produkte neu zu erfinden. Unsere Schattenkreationen bestehen durch ihre Form und ihre Funktionalität. Sie sind stabil, leicht zu öffnen und zu schließen, und sie benötigen wenig Pflege. Ihr Design ist ansprechend und verspielt. Immer mit einem Augenzwinkern, das die Langeweile durchbricht. Sie sind einfach anders. Einzigartig, genau wie Sie. Umbrosa bürgt für bezahlbaren Komfort, nachhaltige belgische Qualität und zuverlässige Funktionalität. Auf raffinierte Art zusammengesetzte Schattenspenden verleihen Ihrem Garten oder Ihrer Terrasse den letzten Schliff.



### NL/ Iets nieuws onder de zon

Zon doet leven. De zon nodigt ons uit om naar buiten te komen. De zon maakt onze leefwereld groter. Maar wanneer de zon iets te fel uit de hoek komt, verlangt u naar een plekje in de schaduw. Parasol betekent letterlijk 'de zon weren'. Een Umbrosa, daarentegen, maakt schaduw. Zodat u kunt blijven genieten van de zon. Zowel voor de particuliere markt als voor de projectmarkt durft Umbrosa bestaande producten opnieuw uit te vinden. Onze schaduwcreaties vallen op door hun vorm en hun werking. Ze zijn robuust, makkelijk te openen en te sluiten én ze vergen weinig onderhoud. Hun design is toegankelijk en speels. Altijd met een knipoog die de saaiheid doorbreekt. Ze zijn gewoon anders. Uniek, net als u.

### IT/ Novità al sole

Il sole dà vita. Il sole ci invita ad uscire. Il sole esalta, espande il mondo in cui viviamo. Ma quando il sole è troppo forte, desideriamo un angolo all'ombra. "Parasole" significa "riparare dal sole". Ogni prodotto Umbrosa crea ombra per vivere al meglio il sole. Sia per il mercato privato sia per quello professionale, Umbrosa osa inventare prodotti diversi da ciò che già esiste. Le nostre creazioni si distinguono per forma e funzionamento innovativi, sono robuste, facili da utilizzare e richiedono poca manutenzione. Il loro design è accessibile e divertente, con fare sfrontato rompono la monotonia di tutti i giorni. Sono semplicemente diversi, unici... come Voi. Umbrosa è lusso possibile, qualità belga garanzia di durata e affidabilità. Ingegnose creazioni d'ombra, tocco finale nel Vostro giardino e terrazzo.

### ES/ Algo nuevo bajo el sol

El sol da la vida, nos anima a salir y hasta parece ensanchar el mundo en el que vivimos; pero cuando brilla un poco más de la cuenta, buscamos un lugar a la sombra. Ahí entran en juego los parasoles Umbrosa, para que disfrute del sol de la manera más refrescante. Tanto en el mercado residencial como en el de proyectos, Umbrosa no duda en reinventar los productos existentes. Nuestras creaciones destacan entre las demás por su forma y utilidad. Son sólidas, fáciles de abrir y cerrar, y requieren poco mantenimiento. Su chispeante diseño siempre ofrece una sonrisa de complicidad para romper con la monotonía. Son diferentes, únicas, como usted. Umbrosa es su garantía de lujo asequible, calidad, fiabilidad y funcionalidad. Estas ingeniosas creaciones serán el exquisito toque final para el jardín o la entrada de su casa.

# UMBROSA

## ECLIPSE®

0.1



Architects Nicolas Verraver and Gauthier Desplanque began their design bureau, NG Design, from their existing architectural bureau, NG Architect. NG Design expresses their passion for design, their love of everything that combines beauty and function, and their respect for the environment.



Eye-catcher and shadow maker all in one. Already while designing it, creating shadow was not the Eclipse's only goal. The Eclipse is a design object, with all of the trump cards of a functional umbrella. The large, elegant ring with its design shade sail offers a tempting, artistic spectacle and reviving shadow.

**FR/** Bijou esthétique et parasol tout en un. Dès les premières phases de développement, l'ombrage n'était pas le seul objectif poursuivi. L'Eclipse est un objet de design avec tous les atouts d'un parasol fonctionnel. La protection solaire tendue au centre d'un grand anneau gracieux crée un spectacle artistique séduisant et une ombre bienfaisante.

**DE/** Eyecatcher und Schattenspender in einem. Schon beim Entwurf des Eclipse war die Aufgabe als Schattenspender nicht das einzige Ziel. Der Eclipse ist ein Designobjekt mit allen Trümpfen eines funktionellen Sonnenschirms. Der große, elegante Ring mit eingespanntem Tuch sorgt für ein attraktives kunstvolles Schauspiel und erfrischenden Schatten.

**NL/** Blickvanger en schaduwmaker in één. Al van bij het ontwerp van de Eclipse was schaduw niet het enige doel. De Eclipse is een designobject met alle troeven van een functionele parasol. De grote, sierlijke ring met opgespannen zonnenscherm zorgt voor een verleidelijk artistiek schouwspel én verkwikkende schaduw.

**IT/** Oggetto che attira l'attenzione e ombrellone in uno. Nella progettazione dell'Eclipse, lo scopo non era solo creare ombra. L'Eclipse è un oggetto design con tutte le carte vincenti di un ombrellone funzionale. L'importante anello elegante con il suo schermo solare teso che offre al tempo stesso uno spettacolo artistico seducente e ombra rigenerante.

**ES/** La sombrilla que acapara las miradas, con un diseño tan cuidado como su función de dar sombra. Se trata de un objeto de diseño, con todas las ventajas de una sombrilla eficaz. El gran y elegante anillo, con su pantalla solar tensada, ofrece un espectáculo artístico y tentador además de una refrescante sombra.

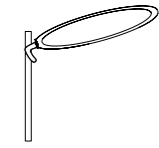

**ECLIPSE®**

see details p. 20

'SIMPLICITY IS NOT THE GOAL, IT'S THE BY-PRODUCT OF A GOOD IDEA'

# UMBROSA

## INFINA®

0.2



Dirk Wynants earned international fame as a trendsetter in outdoor living. More than anyone else, he drew his inspiration from an engaged and creative vision of design. He has attention not only for the material requirements, but he also explores the different ways of answering some of the important themes circulating in society. For him, contemporary design is more than a matter of trendy or attractive objects. Design is about innovative solutions that contribute to making a better world.

**DIRK WYNANTS**

The Infina stands for rest and simplicity. Without the busy knot of ribs and visible frame, the Infina is a real gem of pure aesthetics. The visually very soothing effect provides a clean design, which throws overboard all ballast of the classic center-pole umbrella. The Infina combines a minimalistic design with maximum performance in terms of wind-resistance.

**FR/** L'Infina exhale la sérénité et la simplicité. Sans l'écheveau des baleines et de leurs supports, l'Infina nous offre un bijou d'esthétique pure. L'effet visuel apaisant crée un design sobre qui supprime la lourdeur du parasol sur pied classique. L'Infina combine un langage formel minimaliste à une protection maximale contre le vent.

**DE/** Der Infina steht für Ruhe und Schlichtheit. Ohne dichtes Gewirr von Streben und Halterungen ist der Infina eine Perle reinsten Ästhetik. Der optisch viel Ruhe ausstrahlende Effekt schafft ein klares Design, das allen Ballast des klassischen Sonnenschirms mit Mast über Bord wirft. Der Infina kombiniert minimalistische Formensprache mit maximalem Windwiderstand.

**NL/** De Infina staat voor rust en eenvoud. Zonder het drukke kluwen van baleinen en baleinhouder, is de Infina een pareltje van pure esthetiek. Het visueel zeer rustgevende effect zorgt voor een clean design dat alle ballast van de klassieke stokparasol overboord gooit. De Infina combineert een minimalistische vormtaal met maximale prestaties op het vlak van windweerstand.

**IT/** Infina è sinonimo di riposo e semplicità. Senza corona e le tradizionali stecche, Infina è una perla di pura estetica. Il design pulito garantisce un effetto visivo molto rilassante e "butta a mare" tutte le zavorre del classico ombrellone a palo centrale. Infina combina un linguaggio visivo contemporaneo minimalista con il massimo delle prestazioni in termini di resistenza al vento.

**ES/** Infina apuesta por el descanso y la sencillez. Olvídense de las poco atractivas varillas. Infina es una pura joya del diseño y la estética. El efecto visualmente relajante que ofrece con su diseño depurado arroja por la borda todo el lastre visual de la sombrilla clásica. Infina combina un lenguaje visual minimalista con una máxima resistencia al viento.



**INFINA®  
ROUND**



**INFINA®  
SQUARE**

see details p. 24

'MINIMALISM IS NOT A LACK OF SOMETHING, IT'S SIMPLY THE PERFECT AMOUNT OF SOMETHING'

# UMBROSA

## ICARUS®

0.3



The Antwerp-based design triumvirate Bundl was established in 2008. In conjunction with the client, they sketch the outlines of their new products. That leads to new ideas that challenge every organization to grow further with radical and revolutionary products.

**BUNDL**

With its Icarus, Umbrosa kills two birds with one stone. Inspired by nature, we designed a shadow maker that at the same time can be used as a windscreen. The Icarus embraces and protects. It creates the safe security of a cocoon, while you can enjoy the beautiful weather to the fullest.

**FR/** Avec l'Icarus, Umbrosa fait d'une pierre deux coups. Puisant l'inspiration dans la nature, nous avons conçu un parasol qui protège non seulement du soleil mais servant également d'écran pour le vent. L'Icarus enveloppe et protège. Il crée l'intimité rassurante d'un cocon, tout en vous permettant de profiter pleinement du beau temps.

**DE/** Von der Natur inspiriert, hat Umbrosa einen Schattenspender entworfen, der gleichzeitig auch als Windschutz fungiert. Der Icarus umarmt und schützt. Er schafft die sichere Geborgenheit eines Kokons, während Sie das schöne Wetter in vollen Zügen genießen können.

**NL/** Met de Icarus slaat Umbrosa twee vliegen in één klap. Geïnspireerd door de natuur, ontwierpen we een schaduwmaker die terzelfder tijd ook dienst doet als windscherm. De Icarus omarmt en beschermt. Hij creëert de veilige geborgenheid van een cocon, terwijl u volop kunt genieten van het mooie weer.

**IT/** Con Icarus Umbrosa prende due piccioni con una fava! Ispirati dalla natura, abbiamo disegnato un ombrellone che serve anche da frangivento!! Icarus abbraccia e protegge. La confortevole protezione di un guscio per godere a pieno del bel tempo all'aperto. .

**ES/** Con Icarus, Umbrosa mata dos pájaros de un tiro. Inspirados por la naturaleza, diseñamos una sombrilla que también puede utilizarse como protección del viento. Icarus envuelve y crea un refugio de confort y seguridad, mientras usted disfruta al máximo del buen tiempo.



**ICARUS®**

see details p. 28

'GOOD DESIGN IS A FACILITATOR, BOTH IN TERMS OF THE CHARACTERISTICS OF THE PRODUCT ITSELF AND AS PART OF ITS SURROUNDINGS'

# UMBROSA

## SPECTRA®

0.4



Dirk Wynants earned international fame as a trendsetter in outdoor living. More than anyone else, he drew his inspiration from an engaged and creative vision of design. He has attention not only for the material requirements, but he also explores the different ways of answering some of the important themes circulating in society. For him, contemporary design is more than a matter of trendy or attractive objects. Design is about innovative solutions that contribute to making a better world.

**DIRK WYNANTS**

Because of its unique shape, the Spectra offers an endless variety of positions. This stunning shadow maker, both round and square, combines the beauty of the flat design with the functionality of the fan system. Thanks to this system, the umbrella closes horizontally instead of vertically. A unique and contemporary concept.

**FR/** Avec sa forme unique, le Spectra offre un éventail infini de positions. Ce parasol sobre, au design arrondi ou carré, allie la beauté d'un concept plat à la fonctionnalité d'un système en éventail. Grâce à ce système, le parasol se replie horizontalement. Un concept contemporain unique.

**DE/** Mit seiner außergewöhnlichen Form bietet der Spectra eine unendliche Palette an Positionen. Dieser straffe Schattenspender kombiniert – sowohl rund als auch eckig – die Schönheit des flachen Entwurfs mit der Funktionalität des Fächerprinzips. Dank dieses Systems wird der Sonnenschirm nicht vertikal, sondern horizontal zusammengeklappt. Ein einzigartiges und modernes Konzept.

**NL/** Met zijn unieke vorm biedt de Spectra een eindeloze waaier aan posities. Deze strakke schaduwmaker, zowel rond als vierkant, combineert de schoonheid van het vlakke ontwerp met de functionaliteit van het waaiersysteem. Dankzij dit systeem vouwt u de parasol niet verticaal maar horizontaal dicht. Een uniek en hedendaags concept.

**IT/** Grazie alla sua forma, lo Spectra offre un ventaglio infinito di posizioni. Questo semplice ombrellone rotondo e quadrato, combina la bellezza del design piatto con la funzionalità del sistema a ventaglio. Grazie a questo sistema, l'ombrellone si chiude orizzontalmente invece di verticalmente. Un concetto unico e contemporaneo.

**ES/** Gracias a su forma única, Spectra ofrece una interminable variedad de posiciones. Esta sombrilla rígida, redonda o cuadrada, combina la belleza de su diseño plano con la amplia funcionalidad del sistema abanico. Gracias a este sistema, la sombrilla se puede doblar horizontalmente. Un concepto único y contemporáneo.

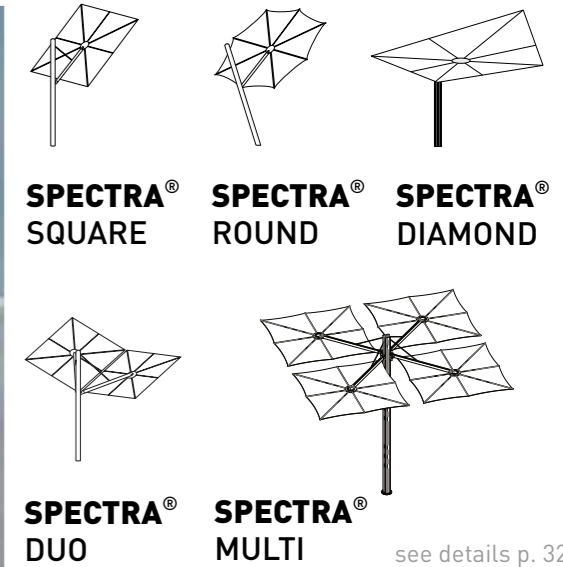

'CONTINUAL  
IMPROVEMENT  
IS AN UNENDING  
JOURNEY'

# UMBROSA

## RIMBOU®

0.5



Pieter Willemys came into contact with Umbrosa when he was finishing his design studies in 2007.

His openness and creativity led to groundbreaking concepts in terms of shade-creation. He has since grown to become responsible for Design and Product Development at Umbrosa.

True to the company's strategy, Pieter wants to design products that are smarter, more creative, less complicated, and surprising. He wants to make shade like no-one has ever before.

**PIETER WILLEMYS**

The Lotus and Venus meet the individual desire for shade. Inspired by the natural shape of a leaf, both shadow makers offer you your own place in the shade.

**FR/** Le Lotus et le Venus répondent aux besoins individuels d'ombrage. Avec leur design en forme de feuille, ces deux parasols vous découpent une place à l'abri du soleil.

**DE/** Der Lotus und der Venus kommen auf dem individuellen Schattenbedarf entgegen. Von der natürlichen Form eines Blattes inspiriert, bieten beide Schattenspendler Ihnen Ihr eigenes Plätzchen im Schatten.

**NL/** De Lotus en Venus spelen in op het individuele verlangen naar schaduw. Geïnspireerd door de natuurlijke vorm van een blad, bieden beide schaduwmakers u uw eigen plekje uit de zon.

**IT/** Le vele Venus e Lotus rispondono al desiderio di ombra individuale. Ispirati alla forma naturale di una foglia, Vi offrono la Vostra zona d'ombra personale.

**ES/** Lotus y Venus son sombrillas para una persona. Inspiradas en la forma natural de una hoja, ambas le ofrecen un lugar privilegiado bajo el sol.

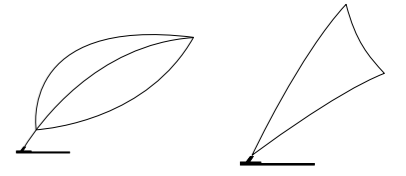
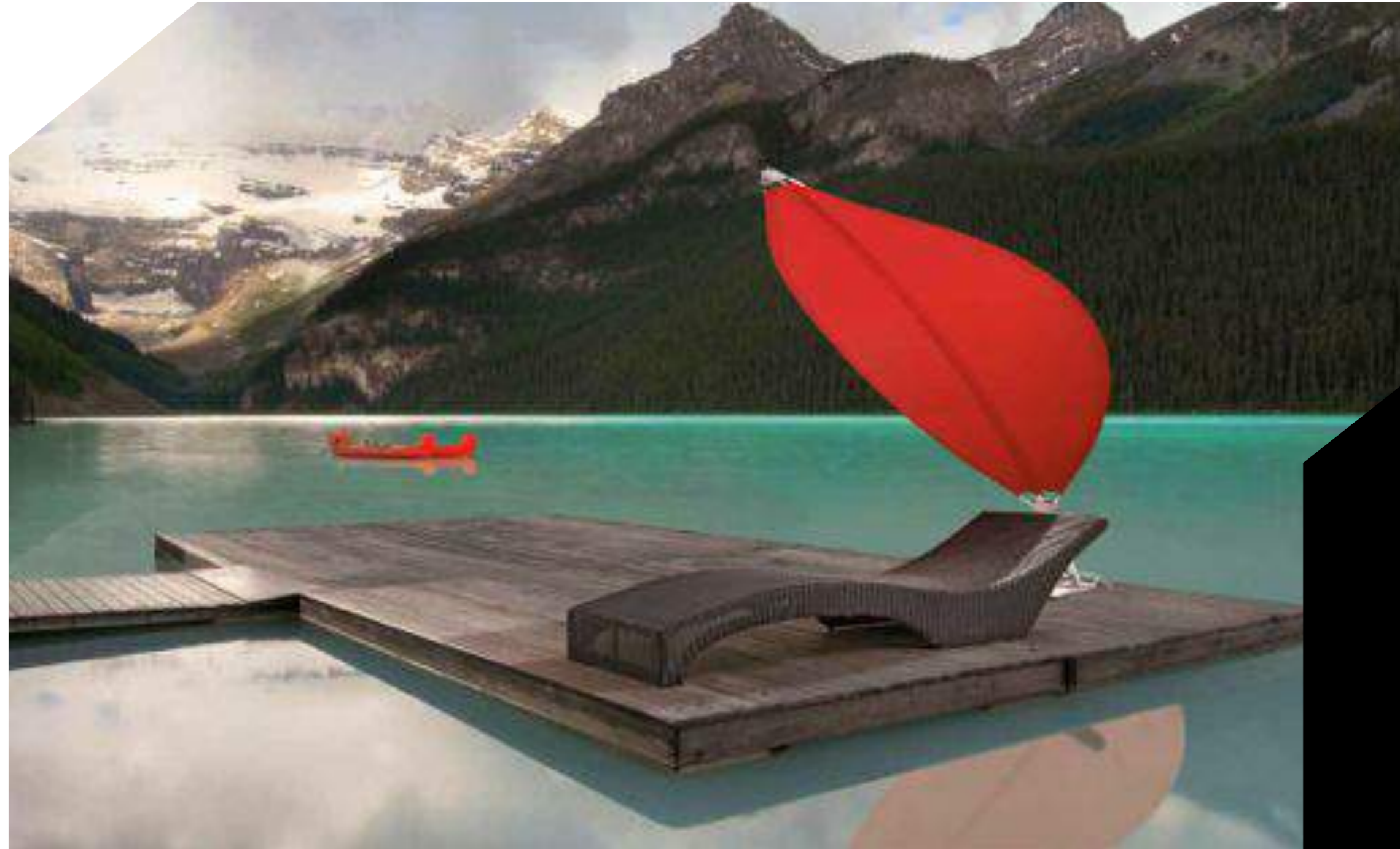

**RIMBOU®**  
**LOTUS**

**RIMBOU®**  
**VENUS**

see details p. 36

'BEAUTY LIES IN  
PERFECT HARMONY  
BETWEEN YOU AND  
NATURE'

# UMBROSA

## INGENUA®

0.6



Pieter Willemyns came into contact with Umbrosa when he was finishing his design studies in 2007. His openness and creativity led to groundbreaking concepts in terms of shade-creation. He has since grown to become responsible for Design and Product Development at Umbrosa. True to the company's strategy, Pieter wants to design products that are smarter, more creative, less complicated, and surprising. He wants to make shade like no-one has ever before.

**PIETER WILLEMYS**

Umbrosa also offers an easy solution for larger surfaces. Thanks to the ingenious sliding mechanism of the Ingenua, you can easily adapt the sail to the circumstances and the environment. The simple lines and modern shapes of the Ingenua are combined with an excellent performance in terms of wind-resistance.

**FR/** Même lorsque vous devez ombrager une large superficie, Umbrosa propose une solution à taille humaine. Grâce à l'ingénieux système coulissant de l'Ingenua, vous adaptez facilement la toile aux conditions et au cadre. Les lignes sobres et les formes modernes de l'Ingenua s'associent à d'excellentes prestations en matière de résistance au vent.

**DE/** Auch wenn größere Schattenflächen erzeugt werden sollen, bietet Umbrosa eine auf den Menschen zugeschnittene Lösung. Dank seines genialen Schiebesystems können Sie das Segel des Ingenua einfach dem Sonnenstand und der Umgebung anpassen. Die klaren Linien und modernen Formen des Ingenua werden mit ausgezeichneter Windbeständigkeit kombiniert.

**NL/** Ook wanneer grotere oppervlakken van schaduw moeten voorzien worden, biedt Umbrosa een oplossing op mensenmaat. Dankzij het ingenieuze schuifstelsel van de Ingenua kunt u het zeil gemakkelijk aanpassen aan de omstandigheden en de omgeving. De sobere lijnen en moderne vormen van de Ingenua worden gecombineerd met uitstekende prestaties op het vlak van windbestendigheid.

**IT/** Anche quando bisogna creare grandi superfici ombreggiate, Umbrosa offre una soluzione a misura d'uomo. Grazie all'ingegnoso sistema scorrevole di Ingenua, è facile adattare la vela all'ambiente ed alle circostanze. Ingenua unisce linee sobrie e modernità a eccellenti prestazioni nella resistenza al vento.

**ES/** Incluso cuando se busca sombra para zonas más grandes, Umbrosa ofrece una solución a escala humana. Gracias al ingenioso mecanismo deslizante de Ingenua, puede adaptar fácilmente el toldo a las circunstancias y al entorno. Las modernas formas y líneas moderadas de Ingenua se combinan con una excelente resistencia al viento.

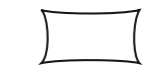

**INGENUA®**  
RECTANGLE



**INGENUA®**  
TRIANGLE



**INGENUA®**  
SQUARE



**INGENUA®**  
PENTA

see details p. 40

'SIMPLICITY IS  
THE ULTIMATE  
SOPHISTICATION'



# UMBROSA

## PARAFLEX®

0.7



In 1999, Peter Leleu conceived of the Paraflex as the solution for a problem that he was confronted with every day of his life... parasols that caught the wind and flew off. A practical, hands-on design that has proven attractive for both the project sector and private individuals. Peter currently heads up sales at Umbrosa.

**PETER LELEU**

Nothing beats the versatility of the human body. As a result, for the Paraflex, we let ourselves be inspired by the manoeuvrability and strength of the human arm. A space-saving solution, without a base and without a pole, which offers you the possibility to create shadow wherever you want it, by means of one, two or more umbrellas, according to your needs. The light and compact Paraflex offers maximum shade and is highly wind-resistant.

**FR/** Rien ne surpasse la polyvalence du corps humain. Pour la gamme Paraflex, nous nous sommes inspirés de la flexibilité et de la solidité du bras humain. Une solution compacte – sans pied et sans support – qui vous permet d’ombrager la zone de votre choix. Avec un, deux ou plusieurs parasols, selon vos besoins. Le Paraflex, léger et compact, offre un ombrage maximal et résiste particulièrement bien au vent.

**DE/** Nichts ist vielseitiger als der menschliche Körper. Für den Paraflex haben wir uns daher von der Gelenkigkeit und Stärke des menschlichen Arms inspirieren lassen. Eine platzsparende Lösung – ohne Fuß und ohne Mast –, dadurch können Sie Schatten erzeugen, wo Sie wollen. Mit einem, zwei oder mehr Schirmen, je nach Ihren Bedürfnissen. Der leichte und kompakte Paraflex spendet maximalen Schatten und ist besonders windbeständig.

**NL/** Niets overtreft de veelzijdigheid van het menselijk lichaam. Voor de Paraflex lieten we ons dan ook inspireren door de wendbaarheid en stevigheid van de menselijke arm. Een plaatsbesparende oplossing – zonder voet en zonder paal – die u de mogelijkheid biedt schaduw te maken waar u het wilt. Met één, twee of meerdere parasols, in functie van uw behoeften. De lichte en compacte Paraflex biedt maximale schaduw en is bijzonder windbestendig.

**IT/** Nulla è più versatile del corpo umano. E proprio alla manovrabilità ed alla forza del braccio umano ci siamo ispirati per lo studio del Paraflex. Una soluzione salva-spazio – senza base o palo – che dà la possibilità di creare ombra dove volete. Con uno, due o più ombrelloni secondo le Vostre esigenze. Paraflex, leggero e compatto, offre la massima ombra ed è molto resistente al vento.

**ES/** Nada supera la versatilidad del cuerpo humano. Por ello, al diseñar el Paraflex nos inspiramos en la maniobrabilidad y la fuerza del brazo humano. Se trata de una solución que ahorra espacio, sin base ni barra, que le permite disfrutar de sombra donde usted quiera, con una o dos sombrillas, según sus necesidades. Ligera y compacta, ofrece una amplia zona de sombra y es altamente resistente al viento.

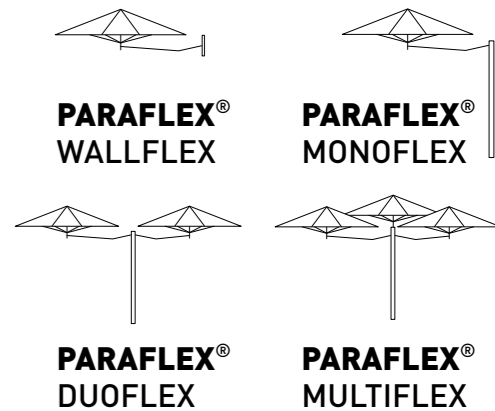

see details p. 46

‘AN ORIGINAL IDEA  
MAKES DESIGN  
DISTINCTIVE BUT  
FUNCTION MAKES  
IT WORK’





ECLIPSE® BY UMBROSA



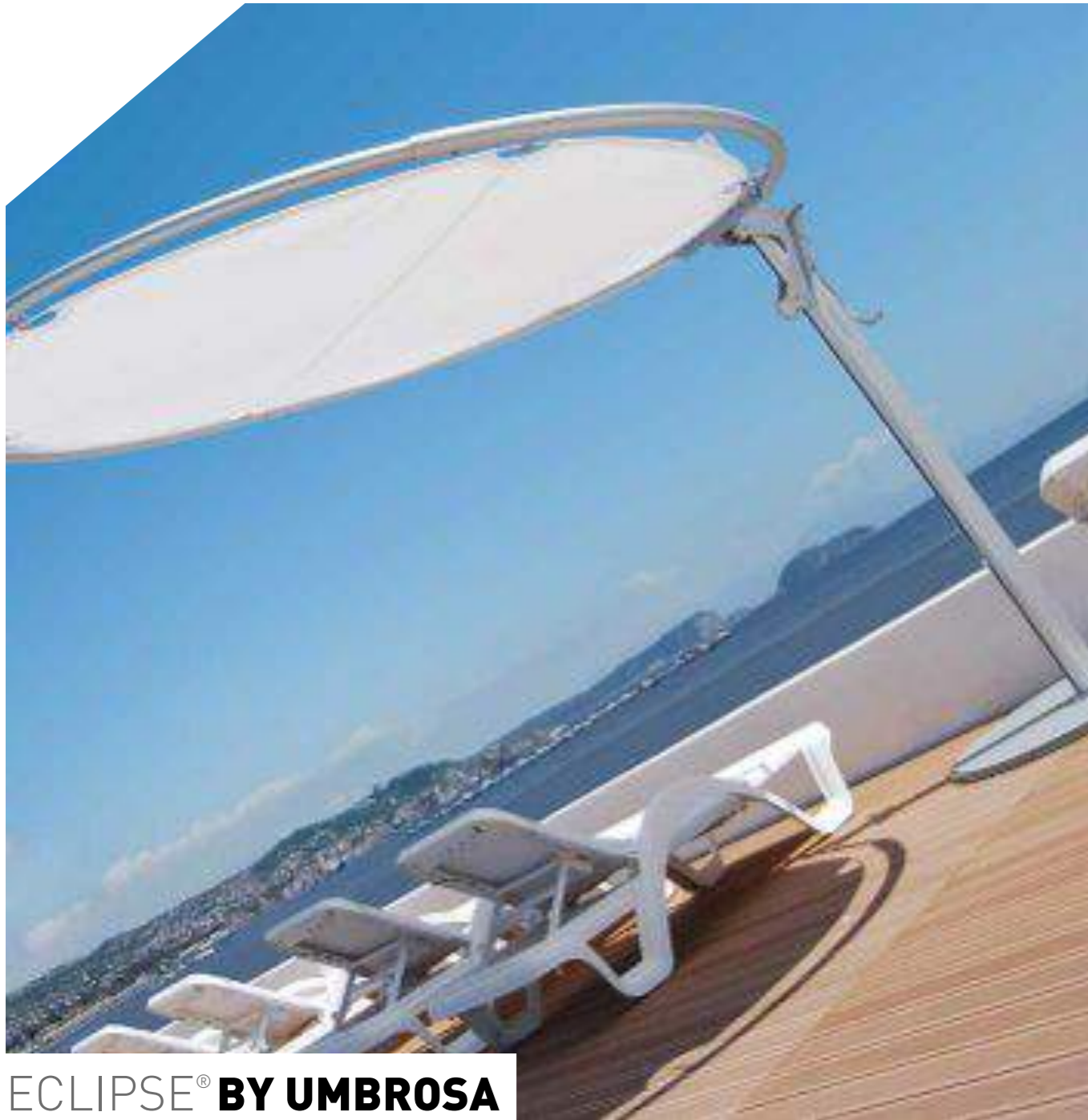

**ECLIPSE® BY UMBROSA**



CHARACTERISTICS

- 1** Easy-to-use handle to adjust height
- 2** Easy to remove the canopy
- 3** 360° rotation of the umbrella
- 4** Protection cover included

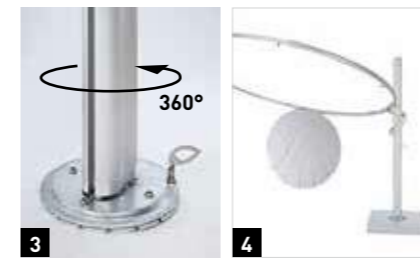
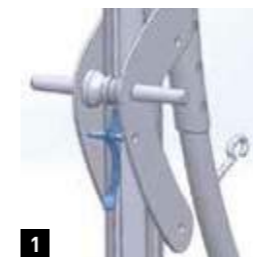

AVAILABLE COLOURS

see p. 52

**TECHNICAL SPECIFICATIONS**

DIMENSIONS

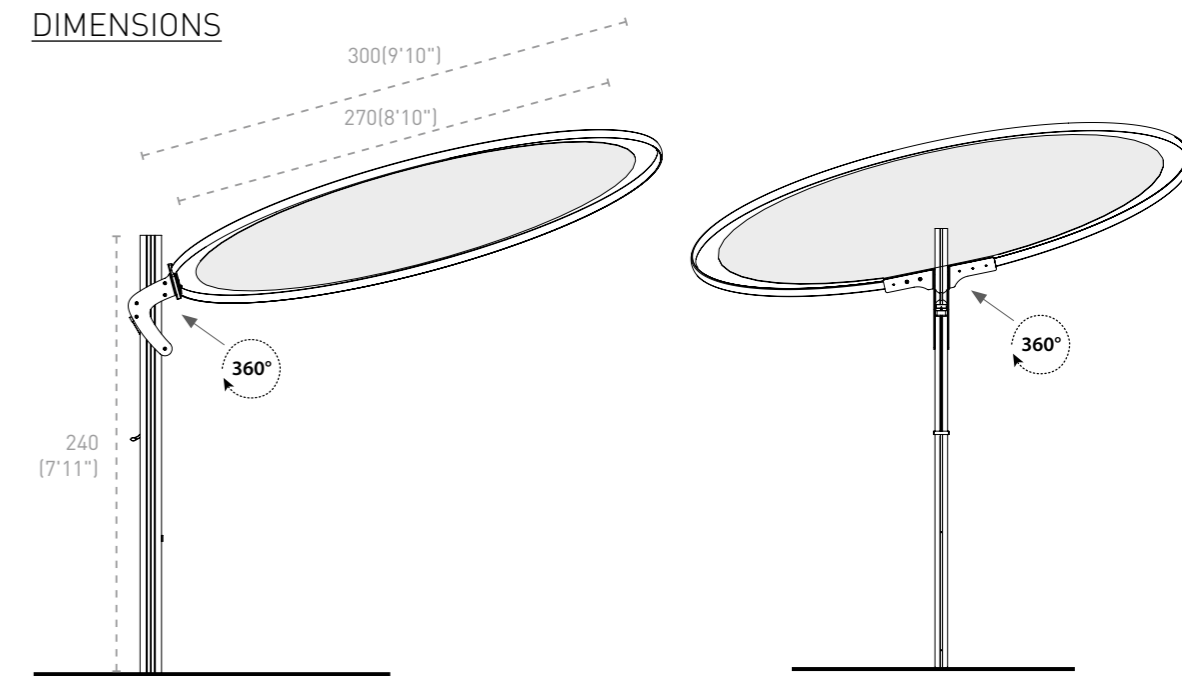

INSTALLATION

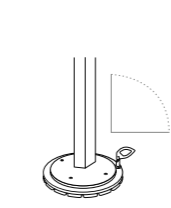

ROTATION SUPPORT\*\*

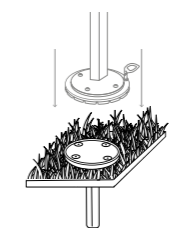

CONCRETE ANCHORAGE FOR ROTATION SUPPORT\*

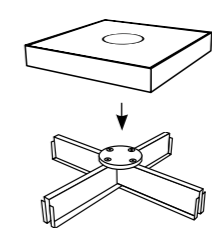

TILE BASE + COVER\*

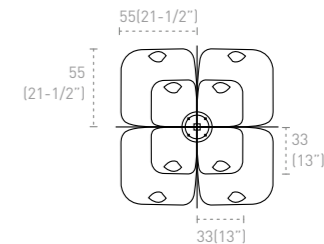

LEAFS\*

\*\*INCLUDED \*OPTIONAL





INFINA® BY UMBROSA

### CHARACTERISTICS

- 1** Easy to open with rope
- 2** Easy to "hide" the rope in pole
- 3** Stainless steel cables
- 4** Movable base
- 5** Protection cover included

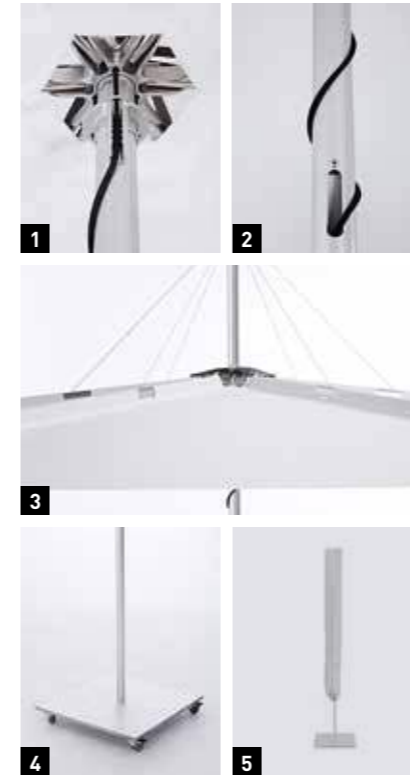

### AVAILABLE COLOURS

see p. 52

### TECHNICAL SPECIFICATIONS

#### DIMENSIONS

##### SQUARE

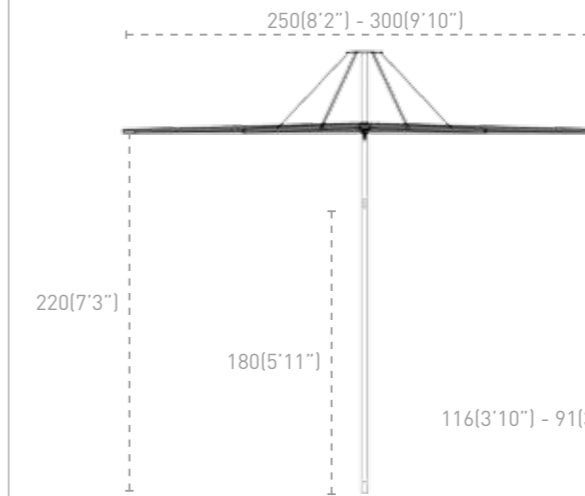

##### ROUND

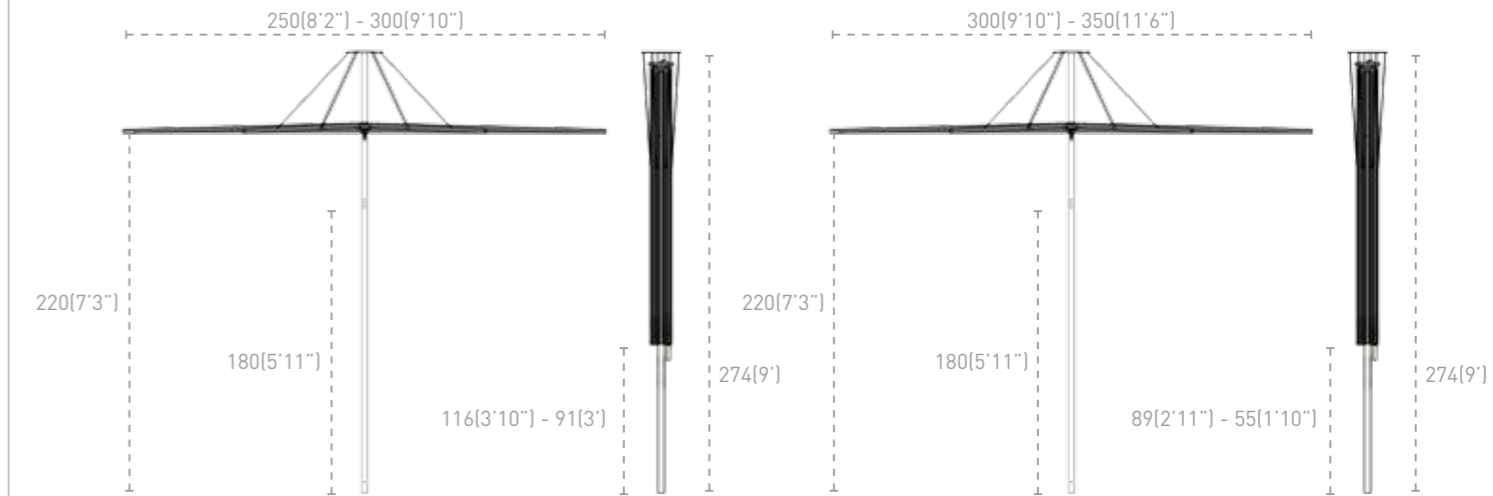

#### INSTALLATION

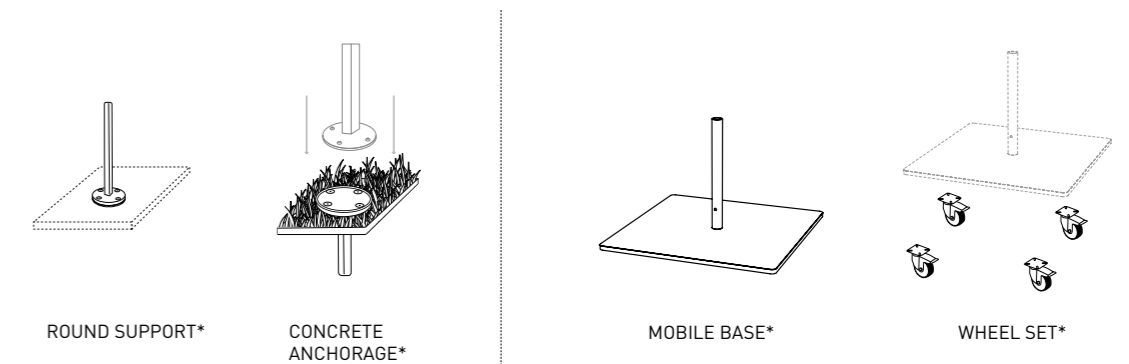

\* OPTIONAL



ICARUS® BY UMBROSA





ICARUS® BY UMBROSA

**CHARACTERISTICS**

- 1** Extendable telescopic mast
- 2** Easy to open
- 3** Smart design
- 4** 360° rotation
- 5** Protection cover included



**AVAILABLE COLOURS**

see p. 52

**TECHNICAL SPECIFICATIONS**

**DIMENSIONS**

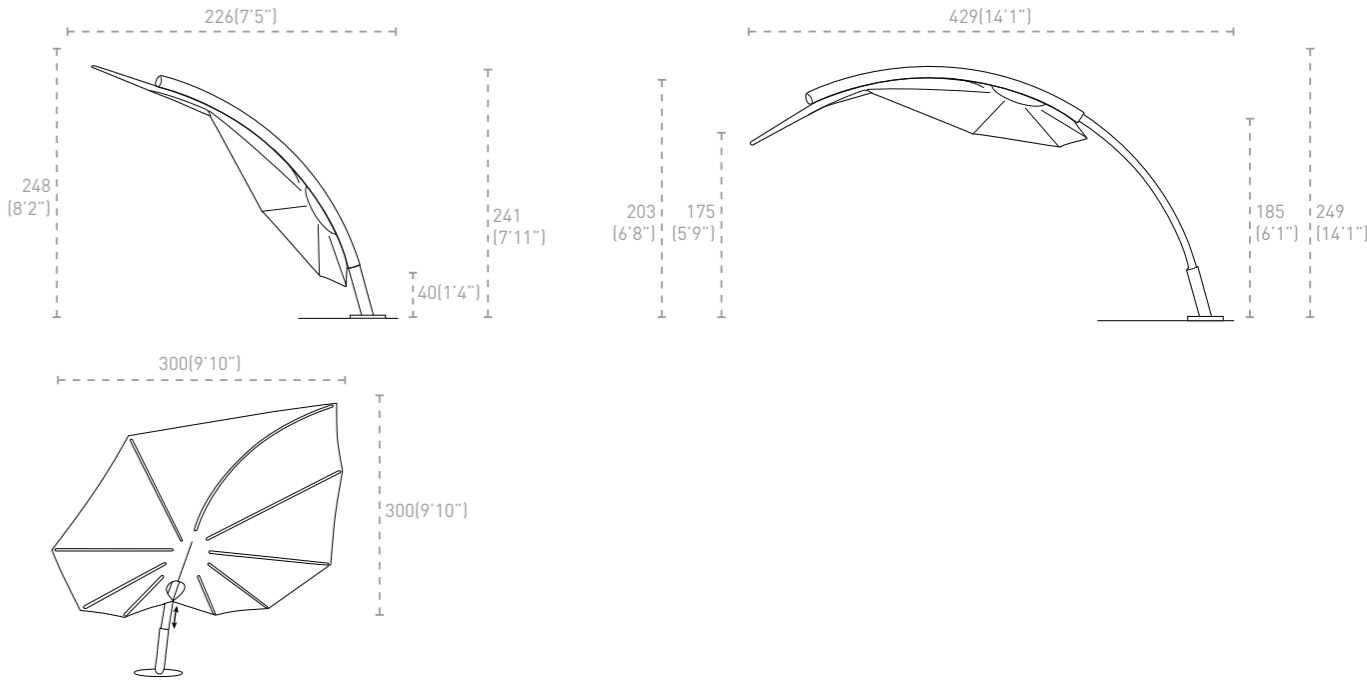

**INSTALLATION**

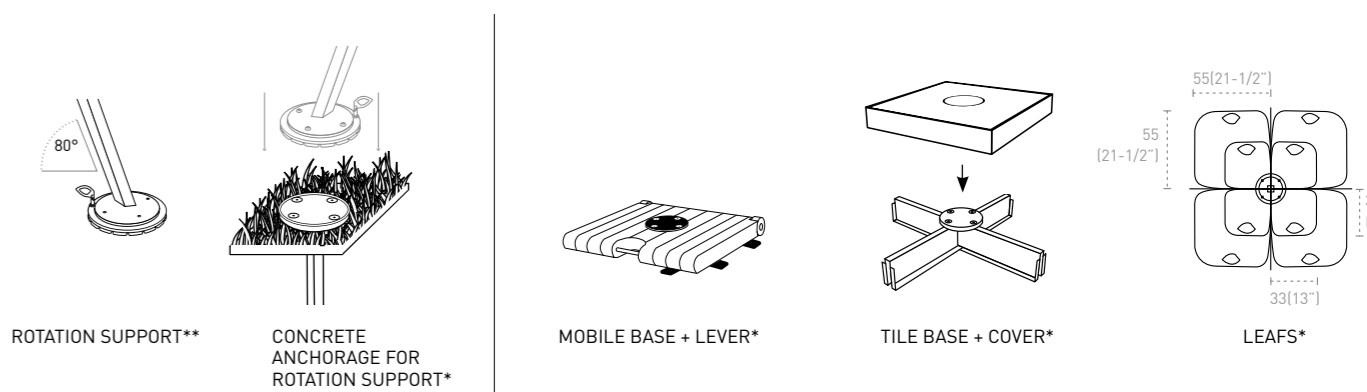

\*\* INCLUDED \* OPTIONAL





SPECTRA® BY UMBROSA





# SPECTRA® BY UMBROSA



## CHARACTERISTICS

- 1 Endless positioning
- 2 Easy-to-use handle for tilting
- 3 Accordion folding
- 4 360° rotation
- 5 Protection cover included

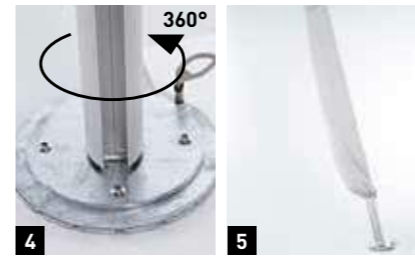

## AVAILABLE COLOURS

see p. 52

## DIMENSIONS

### SQUARE

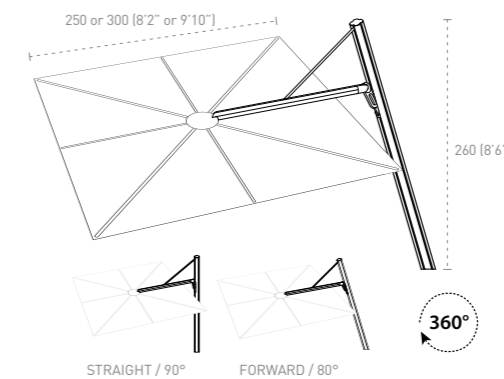

### ROUND

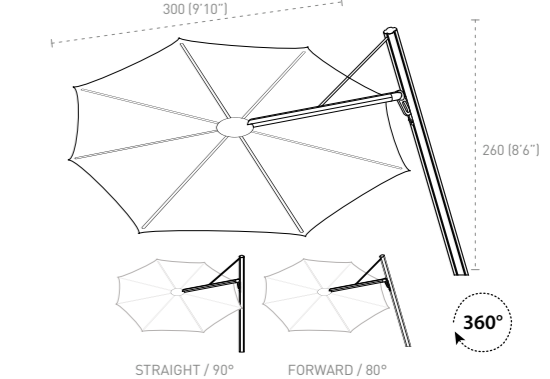

## INSTALLATION

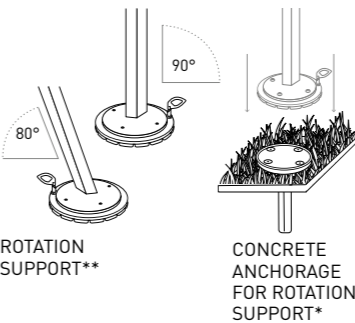

### DUO

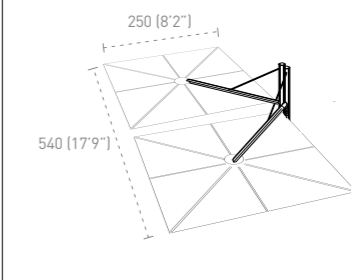

### MULTI

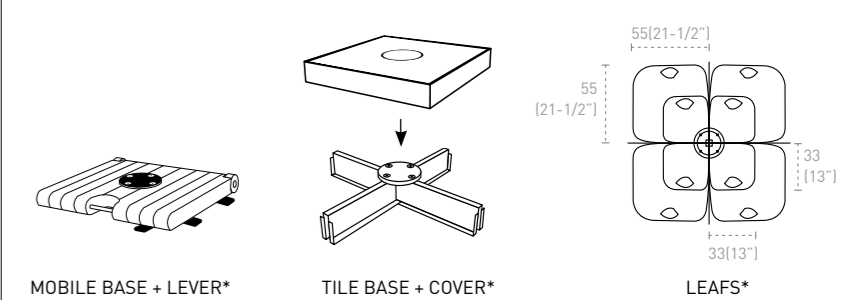
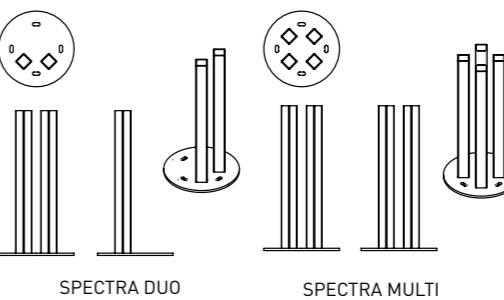
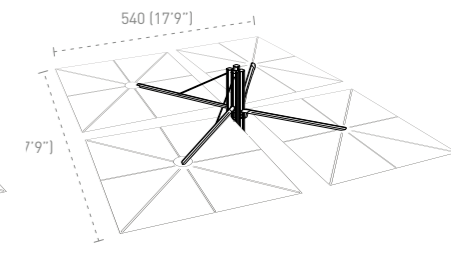

\*\* INCLUDED \* OPTIONAL

## TECHNICAL SPECIFICATIONS



RIMBU VENUS® **BY UMBROSA**





RIMBU LOTUS® BY UMBROSA

CHARACTERISTICS

- 1** Endless positions
- 2** Mobile base with adjustable handle
- 3** Protection cover included



AVAILABLE COLOURS

see p. 52

**TECHNICAL SPECIFICATIONS**

DIMENSIONS

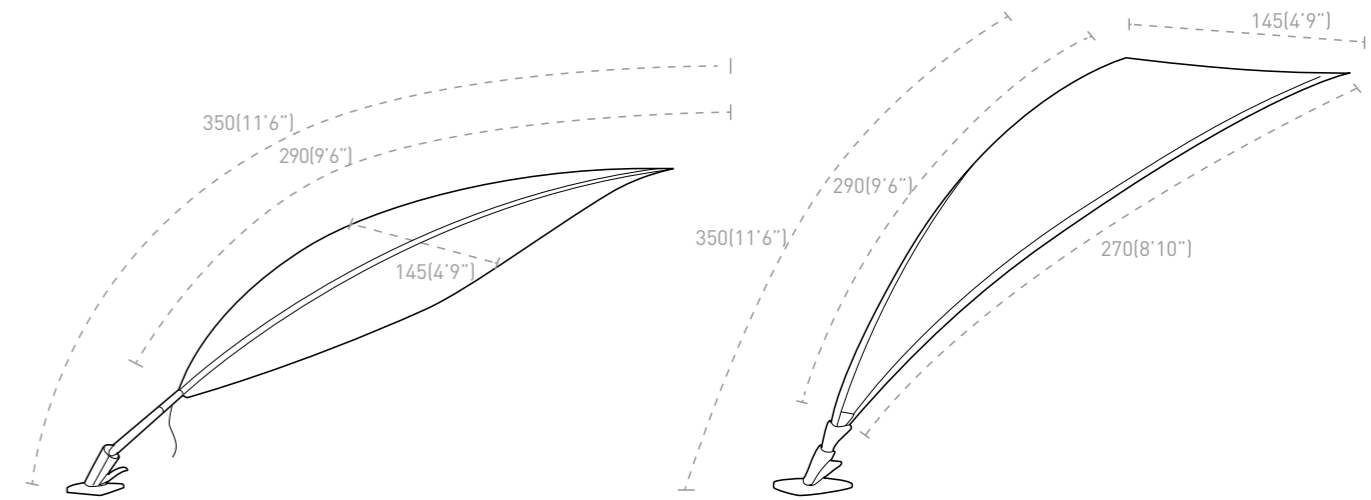

INSTALLATION

**FIXED BASE**

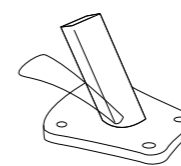

SURFACE FITTING\*\*

**MOVABLE BASE\***

weight: 26 kg - 57lb / with wheels

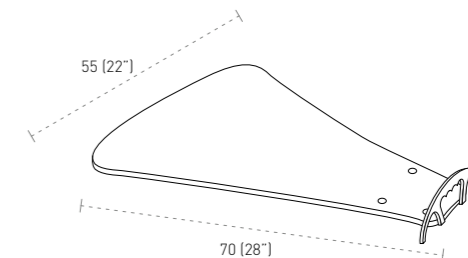

\*\*INCLUDED \*OPTIONAL



INGENUA® **BY UMBROSA**





INGENUA® BY UMBROSA



# TECHNICAL SPECIFICATIONS

## CHARACTERISTICS

- 1** Height adjusting slider mechanism
- 2** Quality finish
- 3** Easy tension
- 4** Easy to store with storage bag



## AVAILABLE COLOURS

see p. 52

## DIMENSIONS

### TRIANGLE

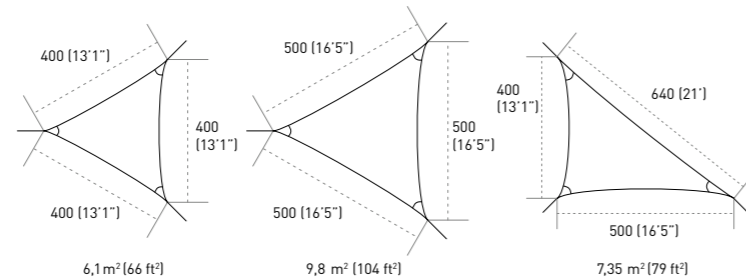

### RECTANGLE

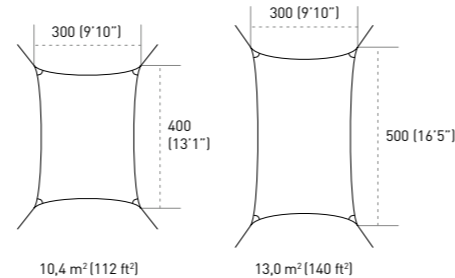

### SQUARE

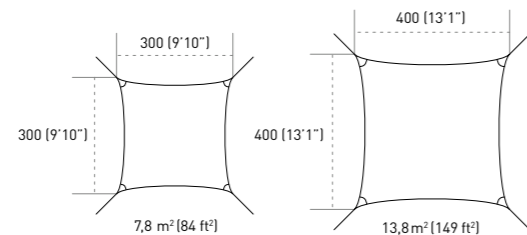

### PENTA

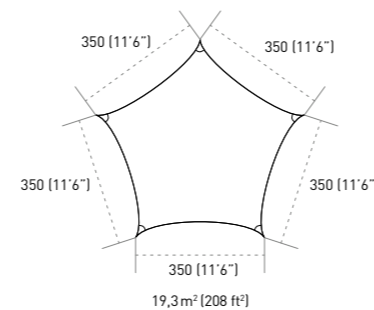

## POLE INSTALLATION

### POSITIONING 90°

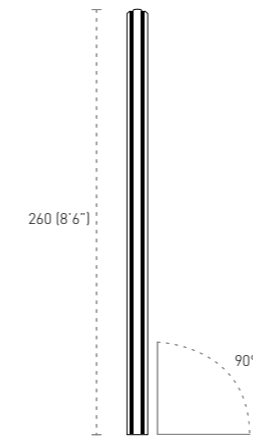

### INSTALLATION 90°

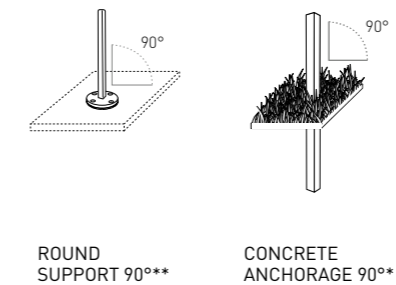

### POSITIONING 75°

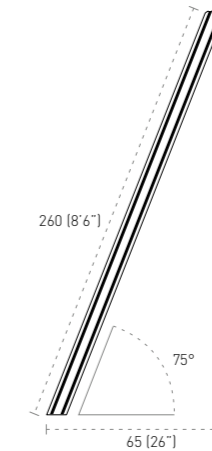

### INSTALLATION 75°

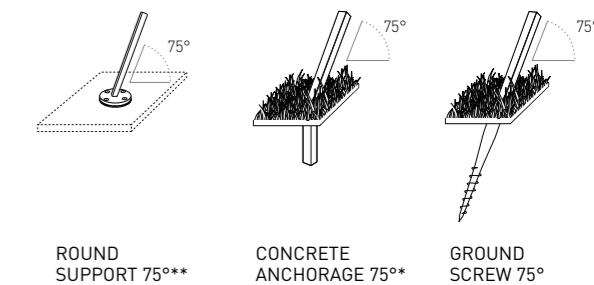

## WALL INSTALLATION

### WALL MOUNT

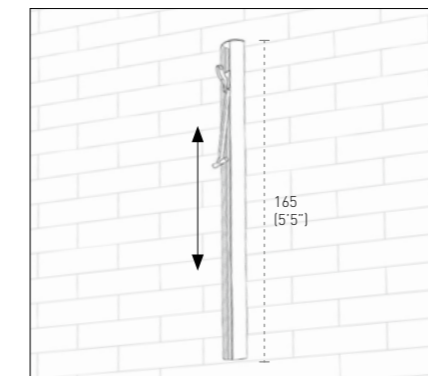

WITH FLEXIBLE SLIDING MECHANISM

### WALLKIT

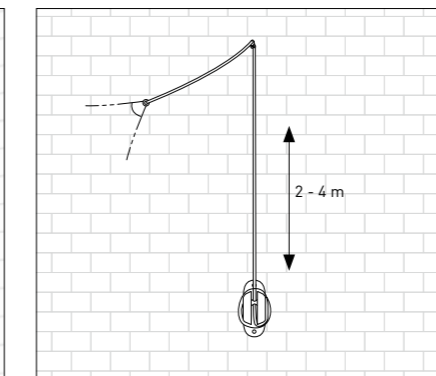

ONE FIXED HEIGHT

PARAFLEX® WALLFLEX



PARAFLEX® BY UMBROSA

PARAFLEX® MONOFLEX



PARAFLEX® DUOFLEX







**PARAFLEX® BY UMBROSA**

CHARACTERISTICS

- 1** Movable shade
- 2** 30° tilt
- 3** High quality frame



AVAILABLE COLOURS

see p. 52

DIMENSIONS

270 HEXAGONAL

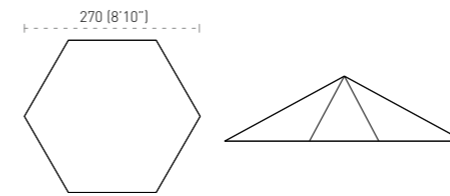

220 HEXAGONAL

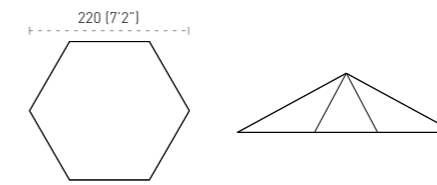

190 SQUARE

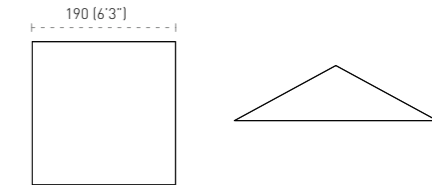

FLEXIBLE ARM

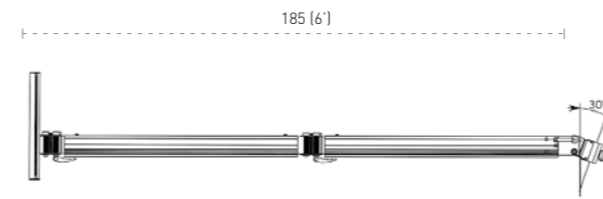

PARAFLEX® CLASSIC STANDARD HOLDER

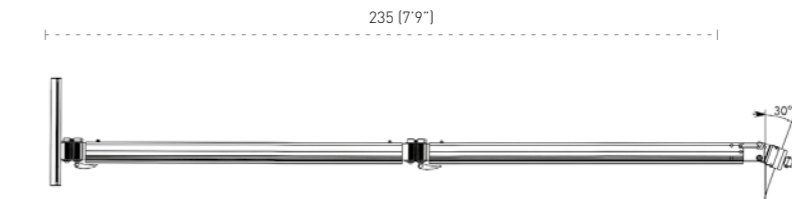

PARAFLEX® CLASSIC LONG SIZE HOLDER

POLE OPTIONS

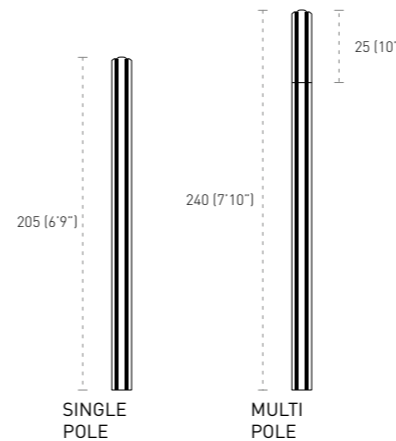

POLE INSTALLATION

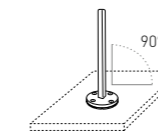

ROUND SUPPORT 90°\*

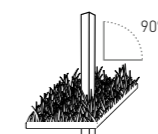

CONCRETE ANCHORAGE 90°\*

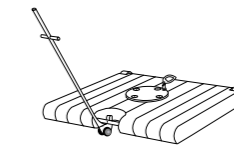

MOBILE BASE + LEVER\*

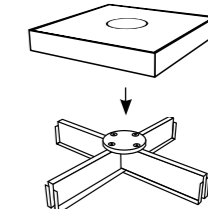

TILE BASE + COVER\*

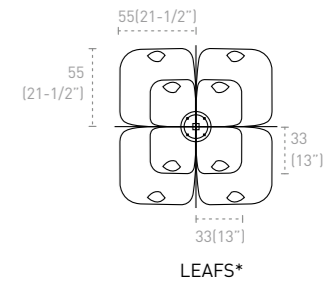

LEAFS\*

\* OPTIONAL

# BASES



## MOBILE BASE + LEVER

Paraflex mono + duoflex /  
Spectra / Eclipse

Material:  
Concrete

Dimensions:  
80 x 80 x 8,5 [31-1/2" SQ x 3-1/3"]

Weight:  
120 kg [265 lbs]

Lever included

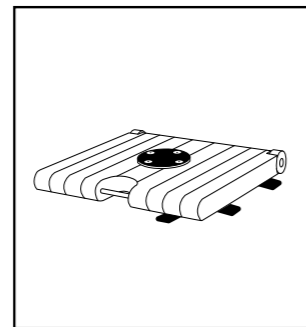

## LEAFS 33 & 55

Icarus / Paraflex / Spectra / Eclipse

Material:  
galvanised steel

Dimensions:  
33 x 33 x 1,2 [13" SQ x 1/2"]  
55 x 55 x 1,2 [21-1/2" SQ x 1/2"]

Weight:  
67,4 kg [149 lbs] to 200 kg [440 lbs]  
pricelist

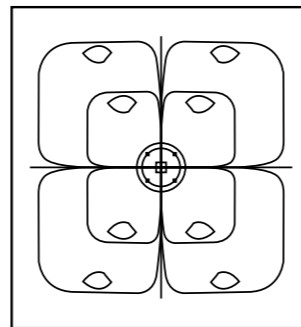

## TILE BASE

Icarus / Paraflex /  
Spectra / Eclipse

Material:  
galvanised steel

Dimensions:  
85 x 85 x 12,5

Weight:  
180 kg (tiles not included)

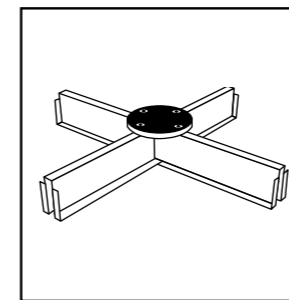

## TILE BASE + COVER

Icarus / Paraflex /  
Spectra / Eclipse

Material: galvanised steel +  
anodized aluminum

Dimensions:  
86 x 86 x 13 [34" SQ x 5"]

Weight:  
189 kg (tiles not included)

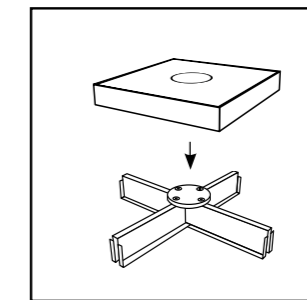

## INFINA BASE

Material: galvanised steel +  
anodized aluminum

Dimensions:  
60 x 60 x 1,6 [24" SQ x 5/8"]

Weight:  
40 kg [88 lbs] – optional: extra weight 20 kg

Wheelset optional

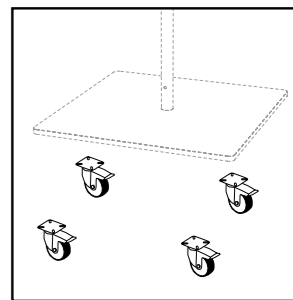

# FABRICS & COLOURS

<b>PREMIUM</b>	Alba	Mint	Mandarine	Sunflower	Camel	Roma	Terra	Taupe	Stonegrey	Red	Nero
<b>LIMITED EDITION</b>	Canvas	Taupe	Granite	Olive	Orange	Lagoon	Paris red	Pink			

OLEFINE 190 G/M<sup>2</sup>



100% SUNBRELLA ACRYL 270 G/M<sup>2</sup>



## DISCOVER THE UMBROSA WORLD OF SHADE



Watch our **videos** and see how functional our shade designs are.

Discover the different **designs** and see more **pictures**.  
Want to be kept updated ? Subscribe to our newsletter.

Become one of our **facebook** fans and receive all updates first hand !

[www.umbrosa.com](http://www.umbrosa.com)

**UMBROSA NV**

Heirweg 198  
8800 Roeselare-Beveren  
Belgium

T +32 51 302 260

F +32 51 302 262

info@umbrosa.com

STAY UPDATED, VISIT :

**WWW.UMBROSA.COM**